

25ML & 50ML VARIABLE SEMI-AUTOMATIC INJECTOR WITH LUER LOCK



The 25ml, and 50ml Semi Automatic Injectors are designed for administration of most vaccines and injectable solutions to livestock. As components in these instruments may be affected by solvents in some commonly used farm chemicals no responsibility will be accepted by the manufacturer should these instruments be used with such products.

INSTRUCTIONS FOR USE: Sterilization

It is essential that this instrument and a supply of needles be thoroughly sterilized before each use.

We recommend a cold water sterilant solution e.g. Milton (or similar product) be used to sterilise the applicator before each use. Follow cold sterilant manufacturer's instructions for sterilisation procedure. If cold water sterilisation is not available, a common method of sterilization is as follows:

1. Draw hot water into the cylinder.
2. Suspend complete instrument in a container of water so it does not touch the bottom. Boil together with the needles for 10 minutes.
3. Remove instrument from container, wrap cloth around handle and pump dry.



Suspending the instrument not only makes it easier to remove, but also prevents damage should the container boil dry. Chemical sterilization with antiseptic solutions is sometimes practised and in such instances the recommendations of the chemical manufacturer should be followed. **DO NOT attempt to sterilize by autoclaving.**

Filling

Before filling from a rubber-sealed glass bottle, ensure that the release locking ring (25) is positioned fully back to disengage the ratchet, allowing the push rod to move freely in either direction. Withdraw push rod fully, expel all air and set injector to the required maximum capacity. Fit needle to syringe and pierce rubber bung on inverted bottle. Introduce air into bottle by pushing the push rod end knob (32). Then, keeping bottle inverted, draw liquid into the cylinder. Repeat this procedure until the syringe is fully charged. Presence of excessive air bubbles indicates an air leak in the instrument or incorrect filling technique.



Care must be taken to ensure the liquid does not come into contact with any part of the operators body. Chemicals may cause injury to the operator.

CLEANING AND MAINTENANCE AFTER USE

1. Remove all traces of material from syringe by flushing thoroughly with a hot water detergent mix. Follow with clean, warm water.
2. Lubricate piston by unscrewing the cylinder and placing a small quantity of NJ Phillips Lubricant, onto the '0' ring (28 or 29).
3. Place a few drops of NJ Phillips Lubricant on all moving parts.
4. When replacing the cylinder, make sure that the push rod is fully back for ease of location, otherwise damage to the cylinder could occur.



DO NOT store your applicator or feed tube full of product. Clean as per the "Care and Maintenance" instructions.

REPLACING PISTON RING

Should it become necessary to replace the piston seal ring, the subsequent procedure must be followed.

1. Pull push rod fully back.
2. Unscrew cylinder from handle.
3. Remove worn '0' ring from piston, taking care not to damage the groove.
4. Lubricate new ring with NJ Phillips Lubricant and fit to piston.
5. Replace cylinder as directed in Care and Maintenance.



Do not attempt to dismantle the dose adjustor assembly as this should never be necessary.

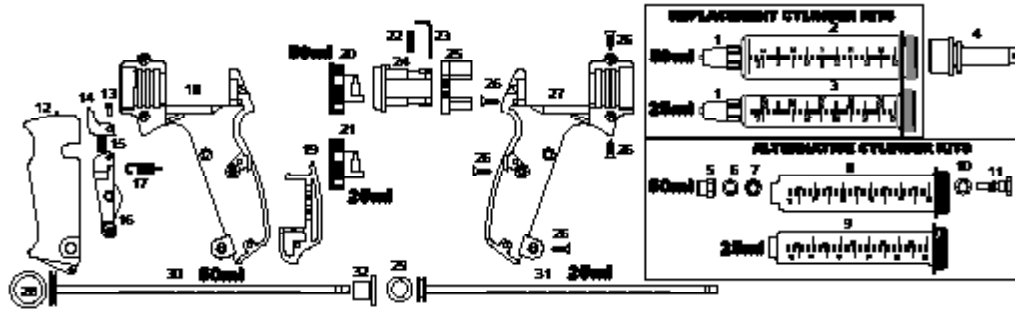

SPARE PARTS AVAILABLE FOR REPLACEMENT CYLINDER KITS: The cylinders supplied with this instrument are made from polypropylene and recommended for superior chemical resistance.

Replacements are:

KIT No.	PART NAME	INCLUDES ILLUSTRATION No.
WX1718	25ml Cylinder & Delivery Cage Assembly	1,3. Translucent cylinder superior chemical resistance.
WX1719	50ml Cylinder & Delivery Cage Assembly	1,2. Translucent cylinder superior chemical resistance.
SXM614	Lever Arm Assembly	13, 14, 15, 16, 17

SPARE PARTS AVAILABLE FOR ALTERNATIVE CYLINDER KITS:

A cylinder made from a different plastic is available which is recommended for superior strength.

The following cylinder kits are available:

WX999	25ml Cylinder & Delivery Cage Assembly	5,6,7,9,10,11. Hard clear cylinder superior strength.
WX1111	50ml Cylinder & Delivery Cage Assembly	5,6,7,8,10,11. Hard clear cylinder superior strength.

25ML & 50ML VARIABLE SEMI-AUTOMATIC INJECTOR WITH LUER LOCK



The 25ml, and 50ml Semi Automatic Injectors are designed for administration of most vaccines and injectable solutions to livestock. As components in these instruments may be affected by solvents in some commonly used farm chemicals no responsibility will be accepted by the manufacturer should these instruments be used with such products.

INSTRUCTIONS FOR USE: Sterilization

It is essential that this instrument and a supply of needles be thoroughly sterilized before each use.

We recommend a cold water sterilant solution e.g. Milton (or similar product) be used to sterilise the applicator before each use. Follow cold sterilant manufacturer's instructions for sterilisation procedure. If cold water sterilisation is not available, a common method of sterilization is as follows:

1. Draw hot water into the cylinder.
2. Suspend complete instrument in a container of water so it does not touch the bottom. Boil together with the needles for 10 minutes.
3. Remove instrument from container, wrap cloth around handle and pump dry.



Suspending the instrument not only makes it easier to remove, but also prevents damage should the container boil dry. Chemical sterilization with antiseptic solutions is sometimes practised and in such instances the recommendations of the chemical manufacturer should be followed. **DO NOT attempt to sterilize by autoclaving.**

Filling

Before filling from a rubber-sealed glass bottle, ensure that the release locking ring (25) is positioned fully back to disengage the ratchet, allowing the push rod to move freely in either direction. Withdraw push rod fully, expel all air and set injector to the required maximum capacity. Fit needle to syringe and pierce rubber bung on inverted bottle. Introduce air into bottle by pushing the push rod end knob (32). Then, keeping bottle inverted, draw liquid into the cylinder. Repeat this procedure until the syringe is fully charged. Presence of excessive air bubbles indicates an air leak in the instrument or incorrect filling technique.



Care must be taken to ensure the liquid does not come into contact with any part of the operators body. Chemicals may cause injury to the operator.

CLEANING AND MAINTENANCE AFTER USE

1. Remove all traces of material from syringe by flushing thoroughly with a hot water detergent mix. Follow with clean, warm water.
2. Lubricate piston by unscrewing the cylinder and placing a small quantity of NJ Phillips Lubricant, onto the '0' ring (28 or 29).
3. Place a few drops of NJ Phillips Lubricant on all moving parts.
4. When replacing the cylinder, make sure that the push rod is fully back for ease of location, otherwise damage to the cylinder could occur.



DO NOT store your applicator or feed tube full of product. Clean as per the "Care and Maintenance" instructions.

REPLACING PISTON RING

Should it become necessary to replace the piston seal ring, the subsequent procedure must be followed.

1. Pull push rod fully back.
2. Unscrew cylinder from handle.
3. Remove worn '0' ring from piston, taking care not to damage the groove.
4. Lubricate new ring with NJ Phillips Lubricant and fit to piston.
5. Replace cylinder as directed in Care and Maintenance.



Do not attempt to dismantle the dose adjustor assembly as this should never be necessary.

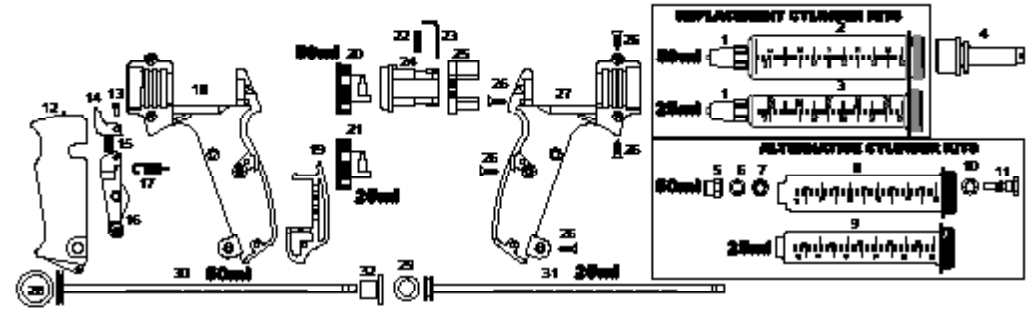

SPARE PARTS AVAILABLE FOR REPLACEMENT CYLINDER KITS: The cylinders supplied with this instrument are made from polypropylene and recommended for superior chemical resistance.

Replacements are:

KIT No.	PART NAME	INCLUDES ILLUSTRATION No.
WX1718	25ml Cylinder & Delivery Cage Assembly	1,3. Translucent cylinder superior chemical resistance.
WX1719	50ml Cylinder & Delivery Cage Assembly	1,2. Translucent cylinder superior chemical resistance.
SXM614	Lever Arm Assembly	13, 14, 15, 16, 17

SPARE PARTS AVAILABLE FOR ALTERNATIVE CYLINDER KITS:

A cylinder made from a different plastic is available which is recommended for superior strength.

The following cylinder kits are available:

WX999	25ml Cylinder & Delivery Cage Assembly	5,6,7,9,10,11. Hard clear cylinder superior strength.
WX1111	50ml Cylinder & Delivery Cage Assembly	5,6,7,8,10,11. Hard clear cylinder superior strength.

NJ PHILLIPS PTY LTD ABN 36 000 082 002 MADE IN AUSTRALIA
ADDRESS: LOCKED BAG 8, GOSFORD, NSW 2250 AUSTRALIA
TELEPHONE: +61 2 4340 2044 FAX: +61 2 4340 1991 EMAIL: njp1@njphillips.com.au



njphillips.com
Our expertise is in your hands.

NJ PHILLIPS PTY LTD ABN 36 000 082 002 MADE IN AUSTRALIA
ADDRESS: LOCKED BAG 8, GOSFORD, NSW 2250 AUSTRALIA
TELEPHONE: +61 2 4340 2044 FAX: +61 2 4340 1991 EMAIL: njp1@njphillips.com.au



njphillips.com
Our expertise is in your hands.

AS OUR POLICY IS ONE OF CONTINUOUS IMPROVEMENT THE MANUFACTURER RESERVES THE RIGHT TO ALTER THESE SPECIFICATIONS AT ANY TIME. ALL PRODUCTS PRODUCED BY NJ PHILLIPS PTY LIMITED, ARE IDENTIFIED BY A UNIQUE BATCH NUMBER. THIS IDENTIFICATION NUMBER IS AFFIXED TO THE PRODUCT TO ALLOW TRACEABILITY BY THE MANUFACTURER AND MUST NOT BE REMOVED IF PRODUCT INTEGRITY IS TO BE MAINTAINED. PAS1337, PAS1338, PAS1357, EAS1358, EAS1362, EAS1363, EAS1388, EAS1408, EAS1409, EAS1586 | QL794-R4

AS OUR POLICY IS ONE OF CONTINUOUS IMPROVEMENT THE MANUFACTURER RESERVES THE RIGHT TO ALTER THESE SPECIFICATIONS AT ANY TIME. ALL PRODUCTS PRODUCED BY NJ PHILLIPS PTY LIMITED, ARE IDENTIFIED BY A UNIQUE BATCH NUMBER. THIS IDENTIFICATION NUMBER IS AFFIXED TO THE PRODUCT TO ALLOW TRACEABILITY BY THE MANUFACTURER AND MUST NOT BE REMOVED IF PRODUCT INTEGRITY IS TO BE MAINTAINED. PAS1337, PAS1338, PAS1356, PAS1357, EAS1358, EAS1362, EAS1363, EAS1388, EAS1408, EAS1409, EAS1586 | QL794-R4