

COPELE

INSTRUCCIONES DE MONTAJE
CORRAL MÓVIL
DIMENSIONES: 4,4x2,5x1,8 11 m²
CÓDIGO: 30162

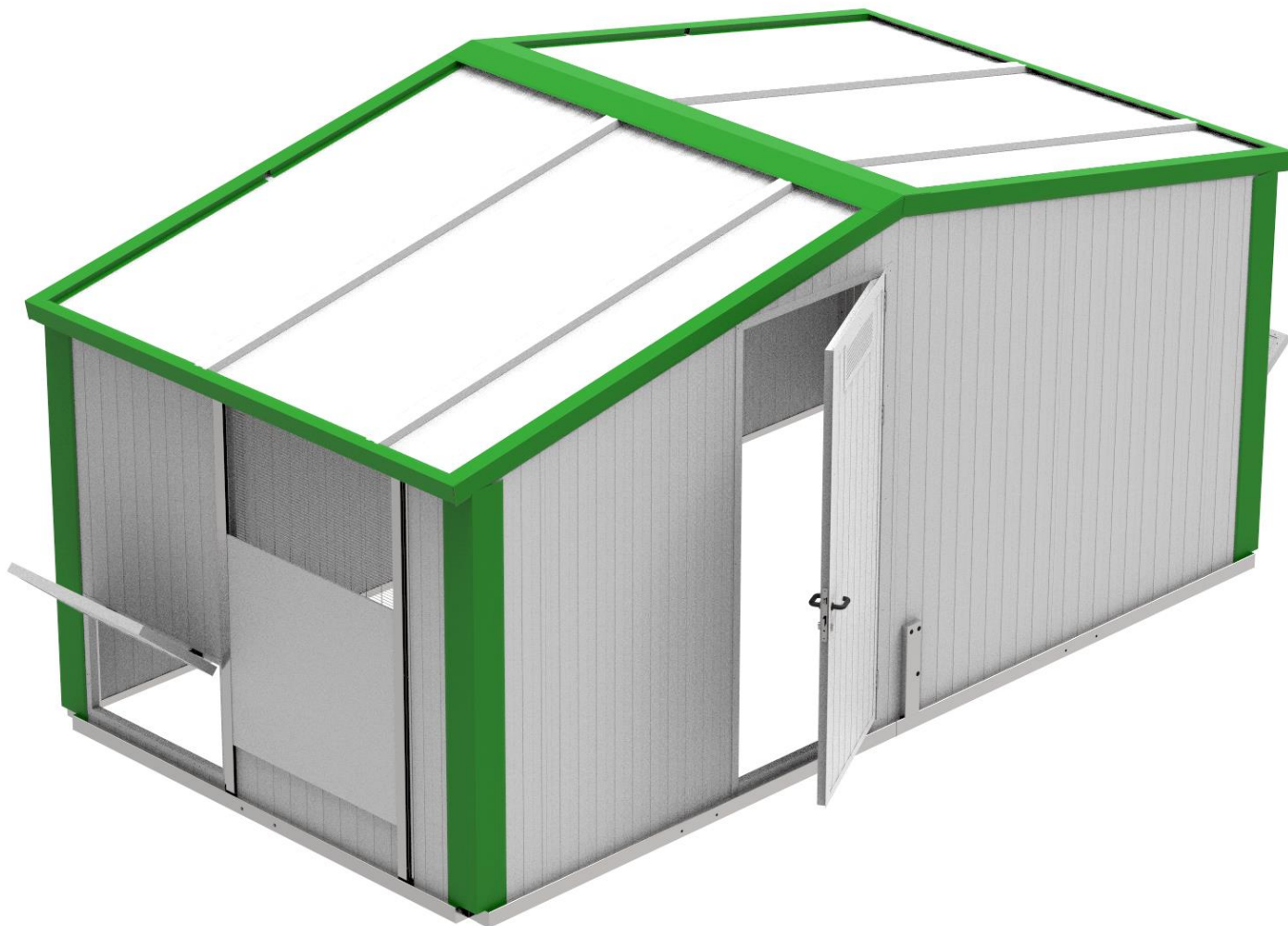

+ KIT DESPLAZAMIENTO:
CÓDIGO: 30163



LISTADO DE ELEMENTOS:

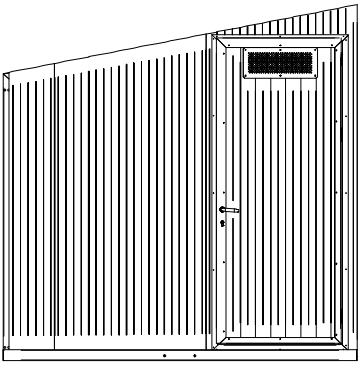

53016201
Frontis-1 puerta
1 Uds

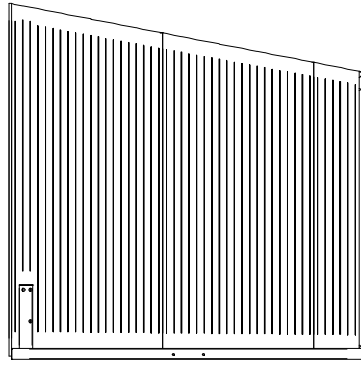

53016202
Frontis-2 sin puerta
1 Uds

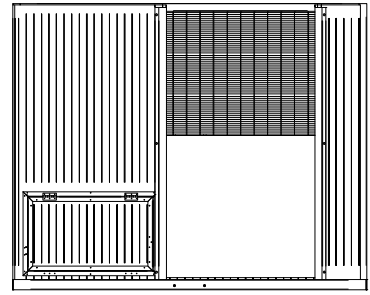

53016205
Lateral sandwich
2 Uds

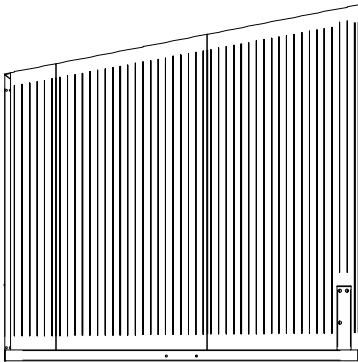

53016203
Frontis-3 rueda
1 Uds

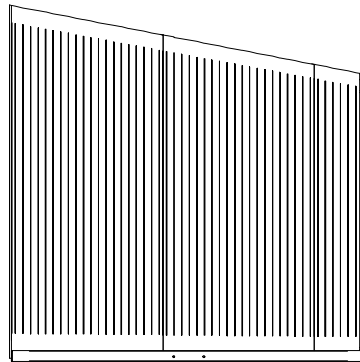

53016204
Frontis-4 sin rueda
1 Uds

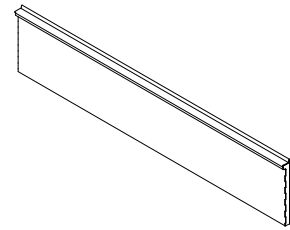

1/2 Panel macho
cub 40mm
1 Uds

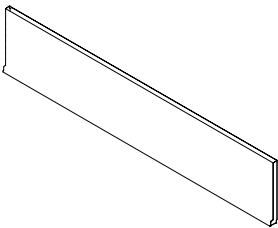

1/2 Panel hembra
cub 40mm
1 Uds

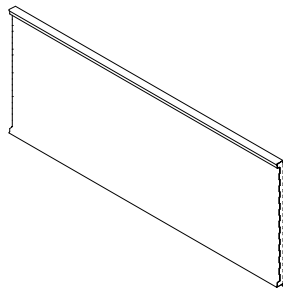

Panel cub 40mm
4 Uds



53016209
Esquinera vert L
4 Uds

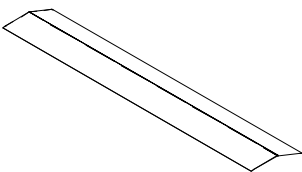

53016207
Cumbrera L
2 Uds

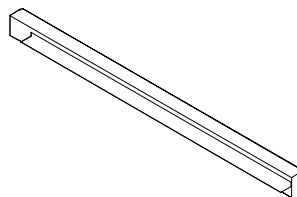

53016208
Canalón L
4 Uds

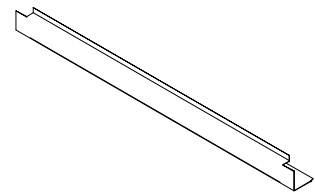

53016210
Cantonera longit L
8 Uds

53016206
Correa C
4 Uds

ACCESORIOS:

ACCESORIOS CORRAL MÓVIL		
CÓDIGO	DESCRIPCIÓN	UNIDAD
77000300	TORNILLO DIN 931 M10x120	28
77111700	TUERCA DIN 934 M10	28
77230500	ARANDELA DIN 125	56
77017000	AUTOTALADRANTE DIN 7504 5.5x22	110
	AUTOTALADRANTE DIN 7504 5.5x82	48

FASE 1: ESTRUCTURA

1.1)

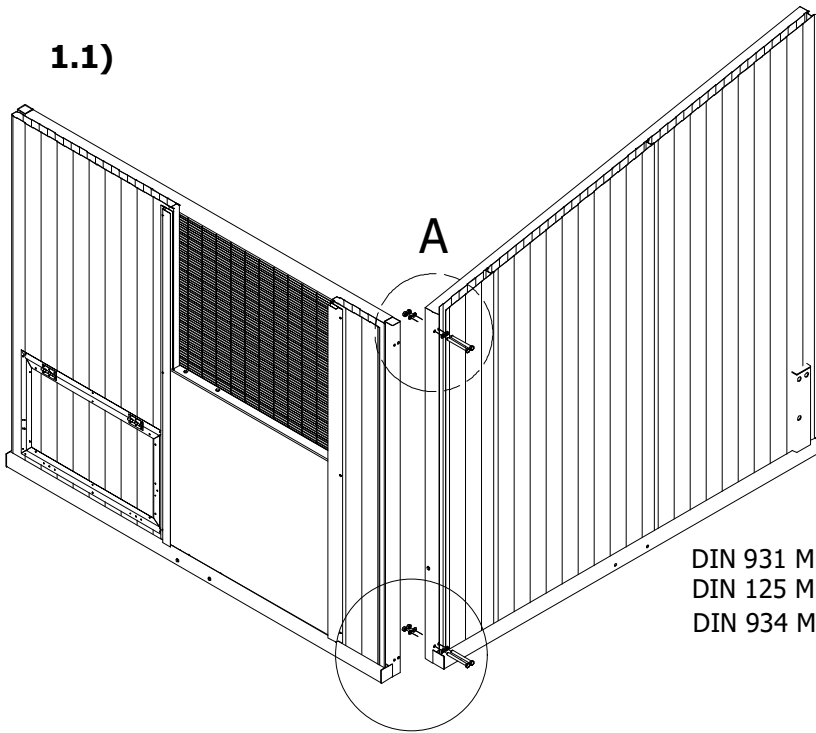

DIN 931 M10x120 (x28)
DIN 125 M10 (x56)
DIN 934 M10 (x28)

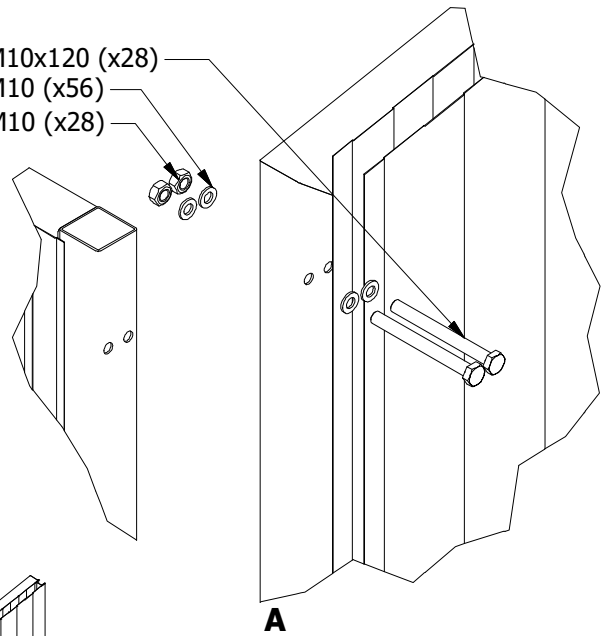

1.2)

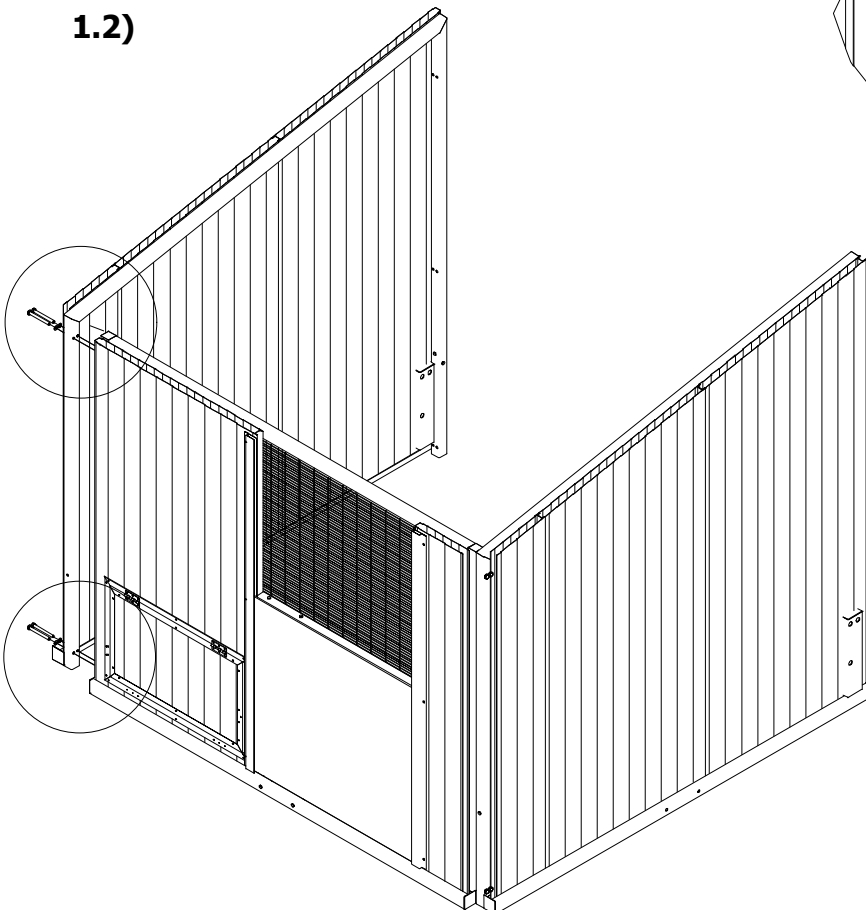

1.3)

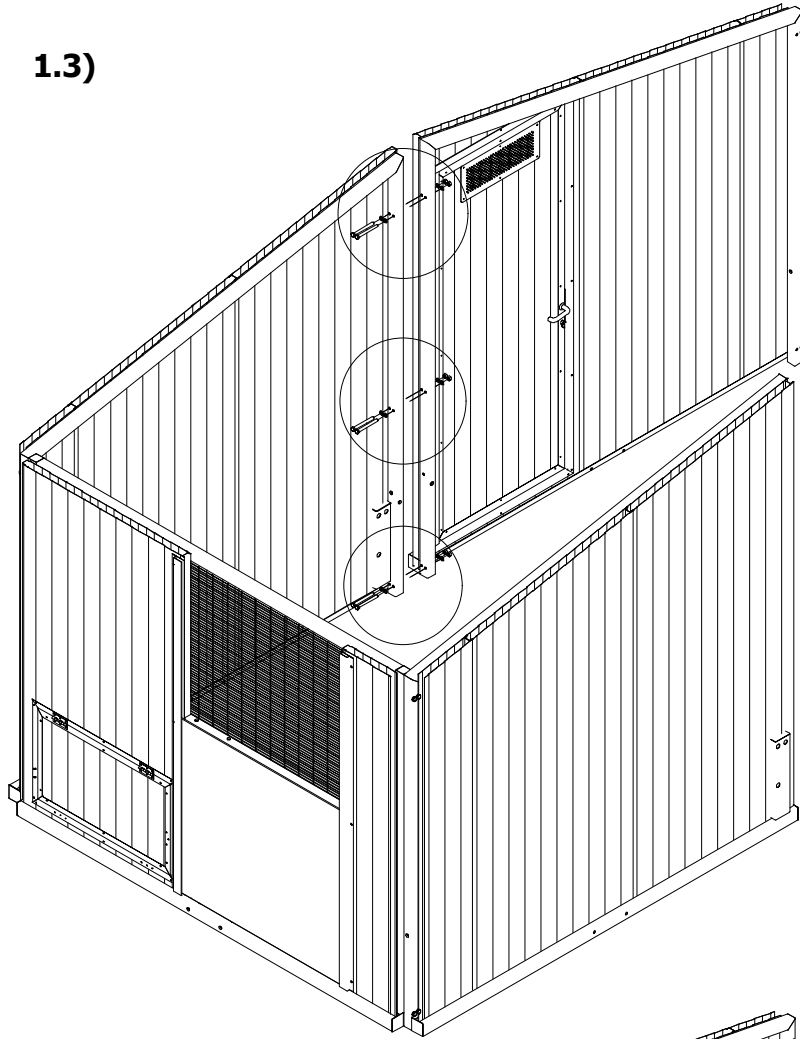

1.4)

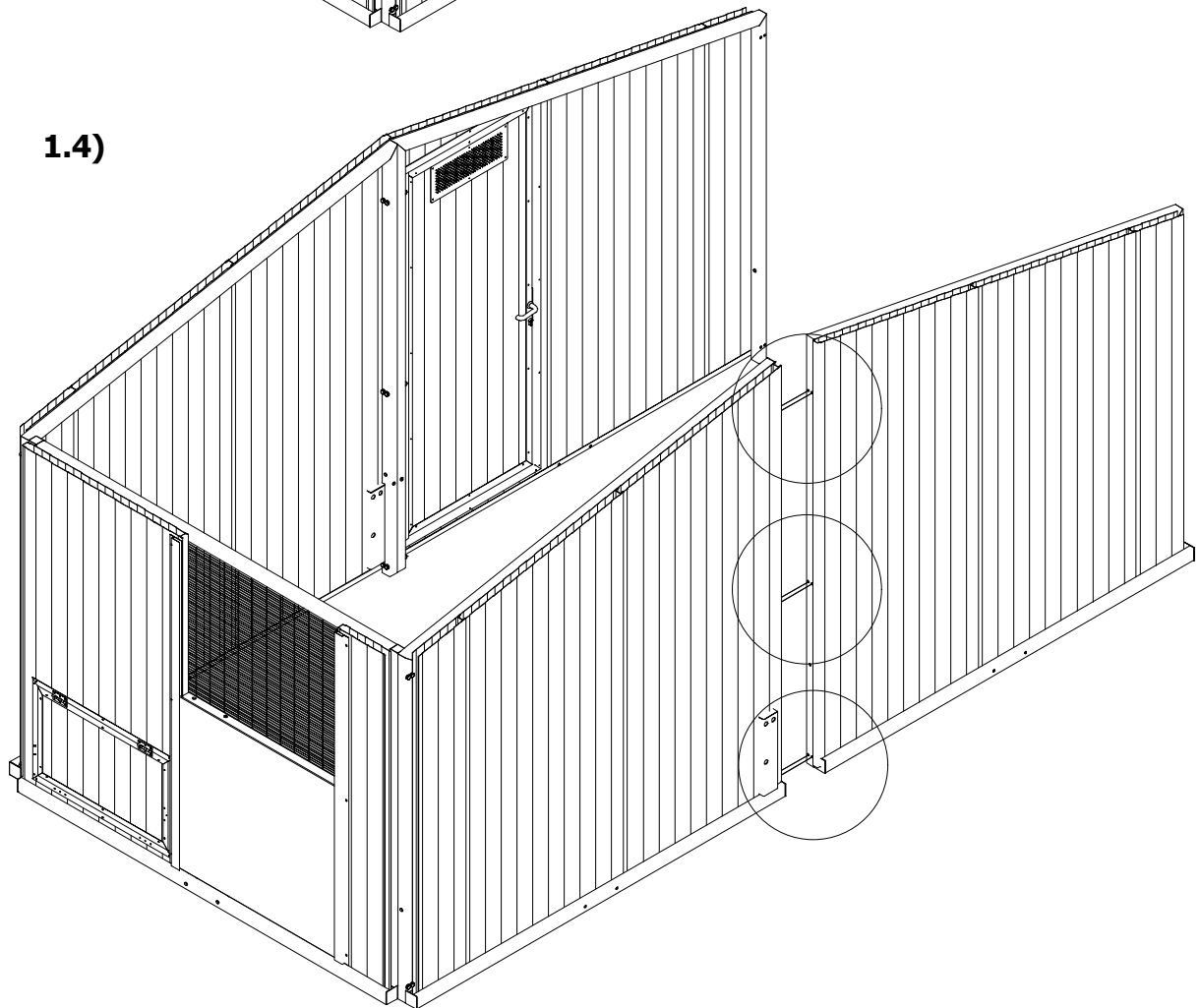

1.5)

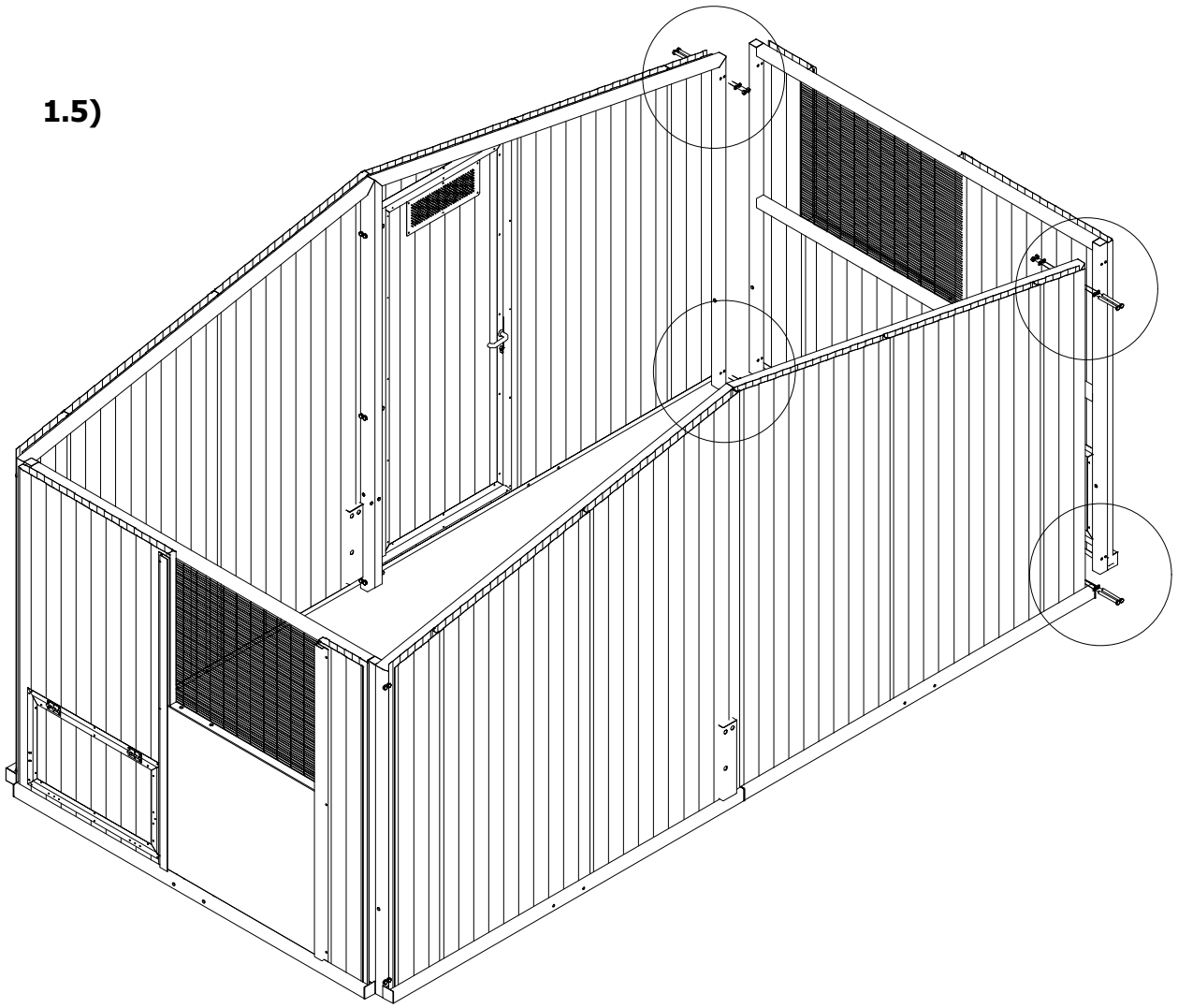

FASE 2: CUBIERTA

2.1)

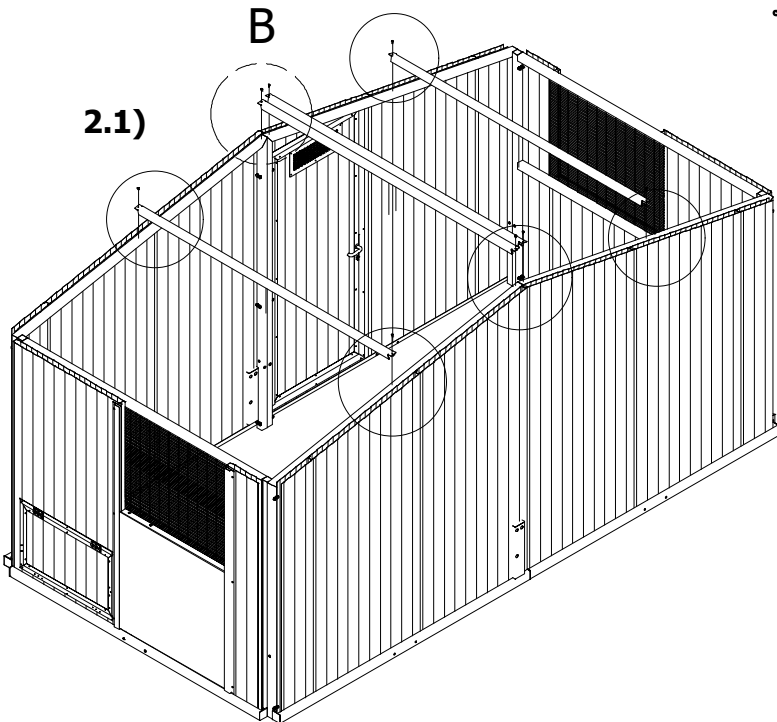

DIN 7504 5.5x22 (x8)

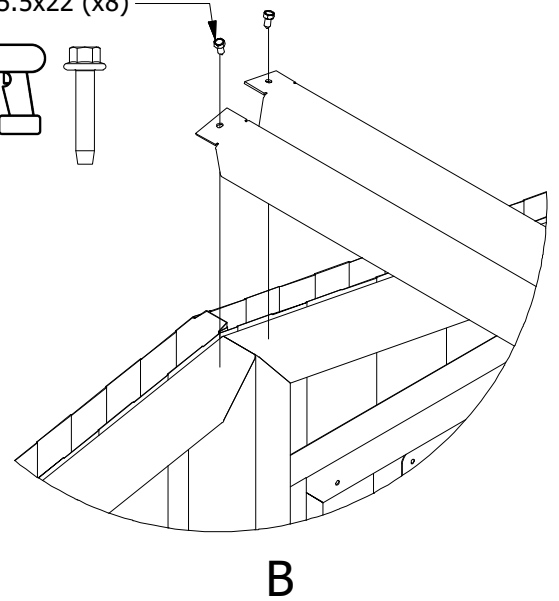
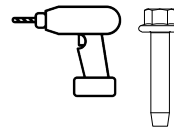

2.2)

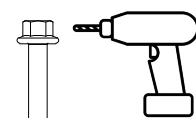
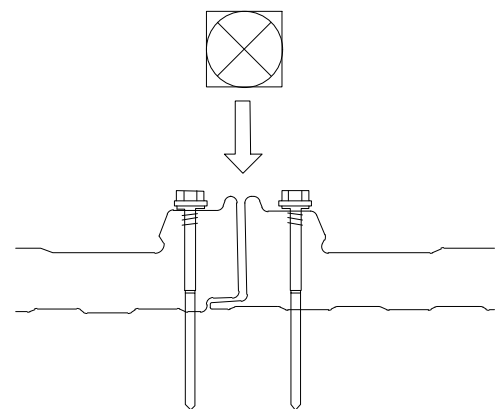
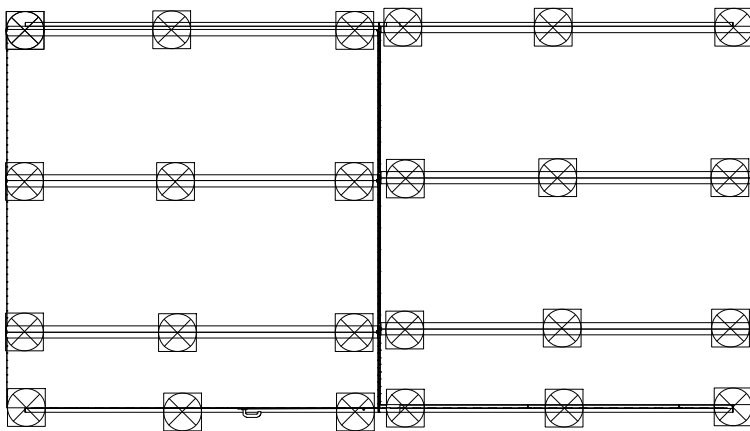
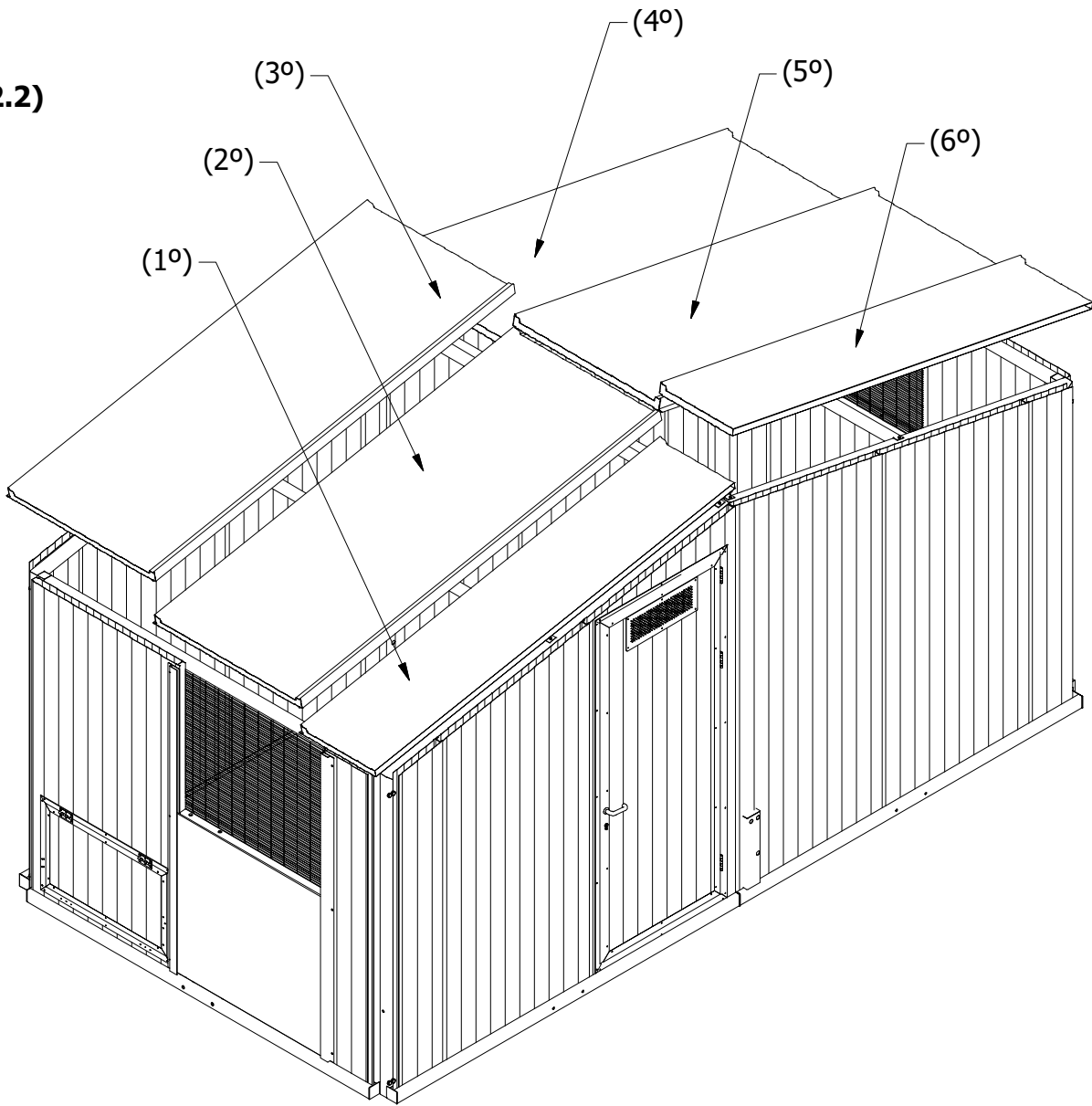

DIN 7504 5.5x82 (x48)

2.3)

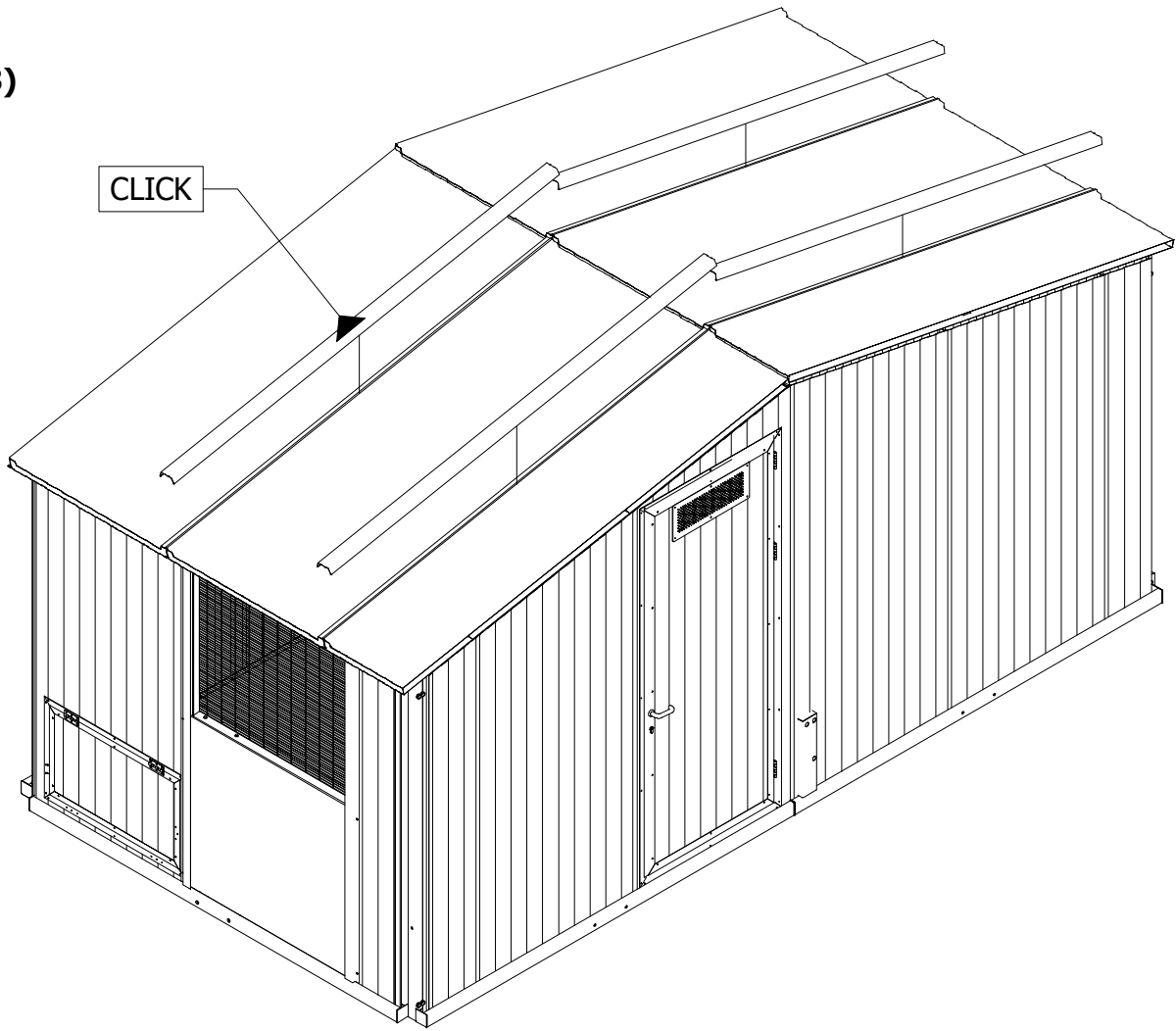

2.4)

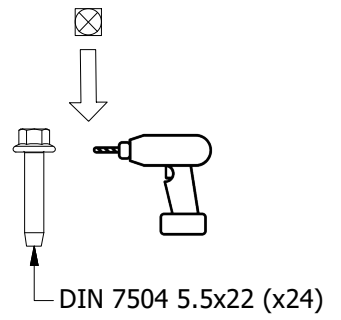
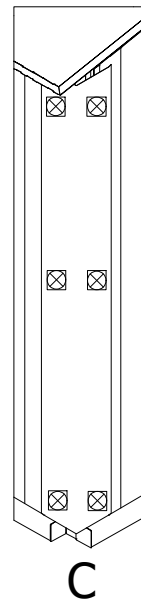
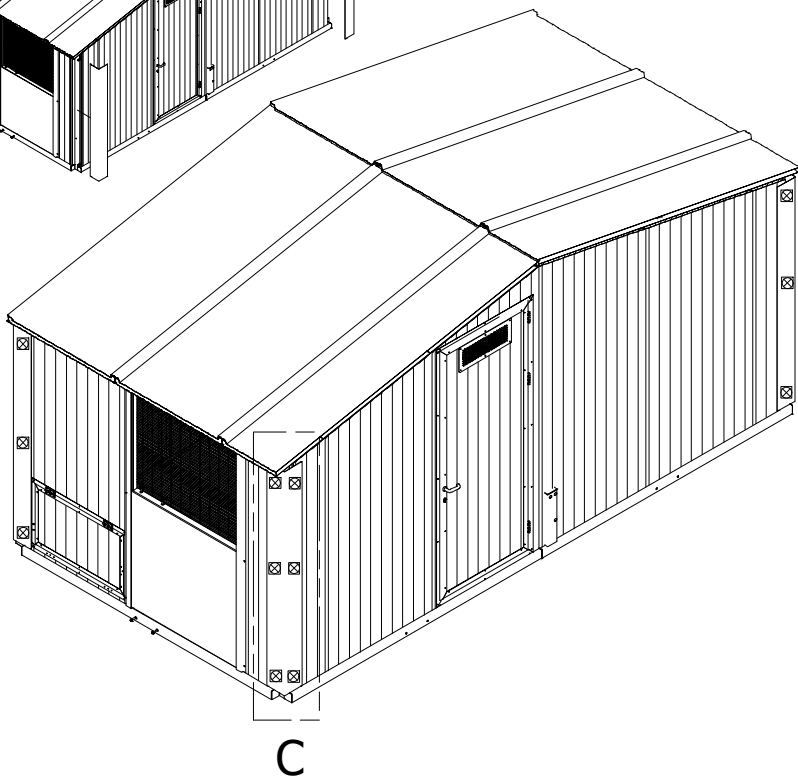
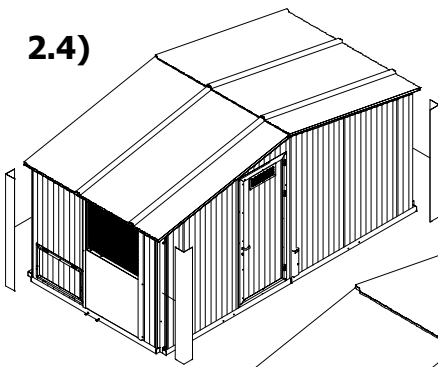

2.5)

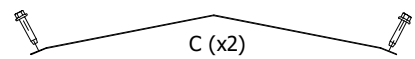
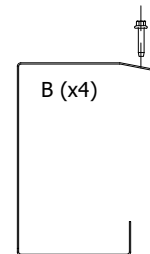
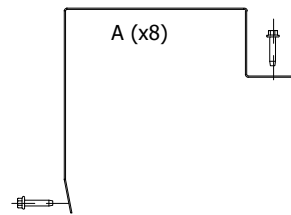
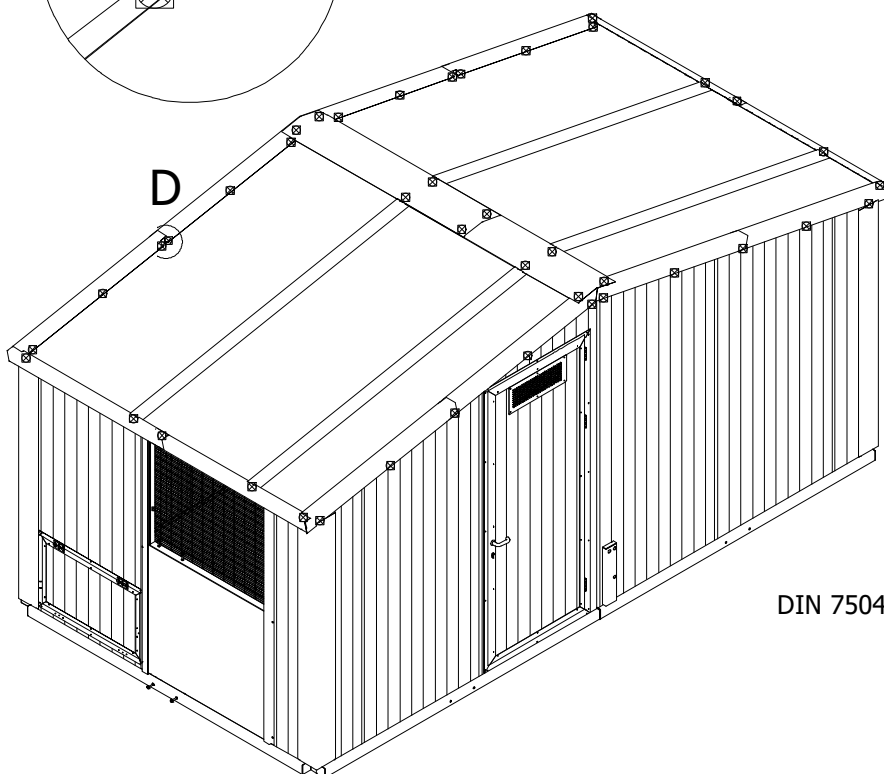
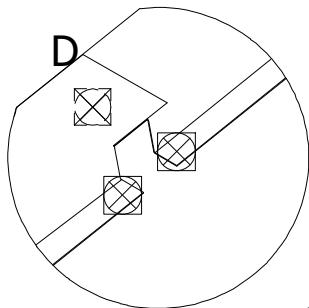
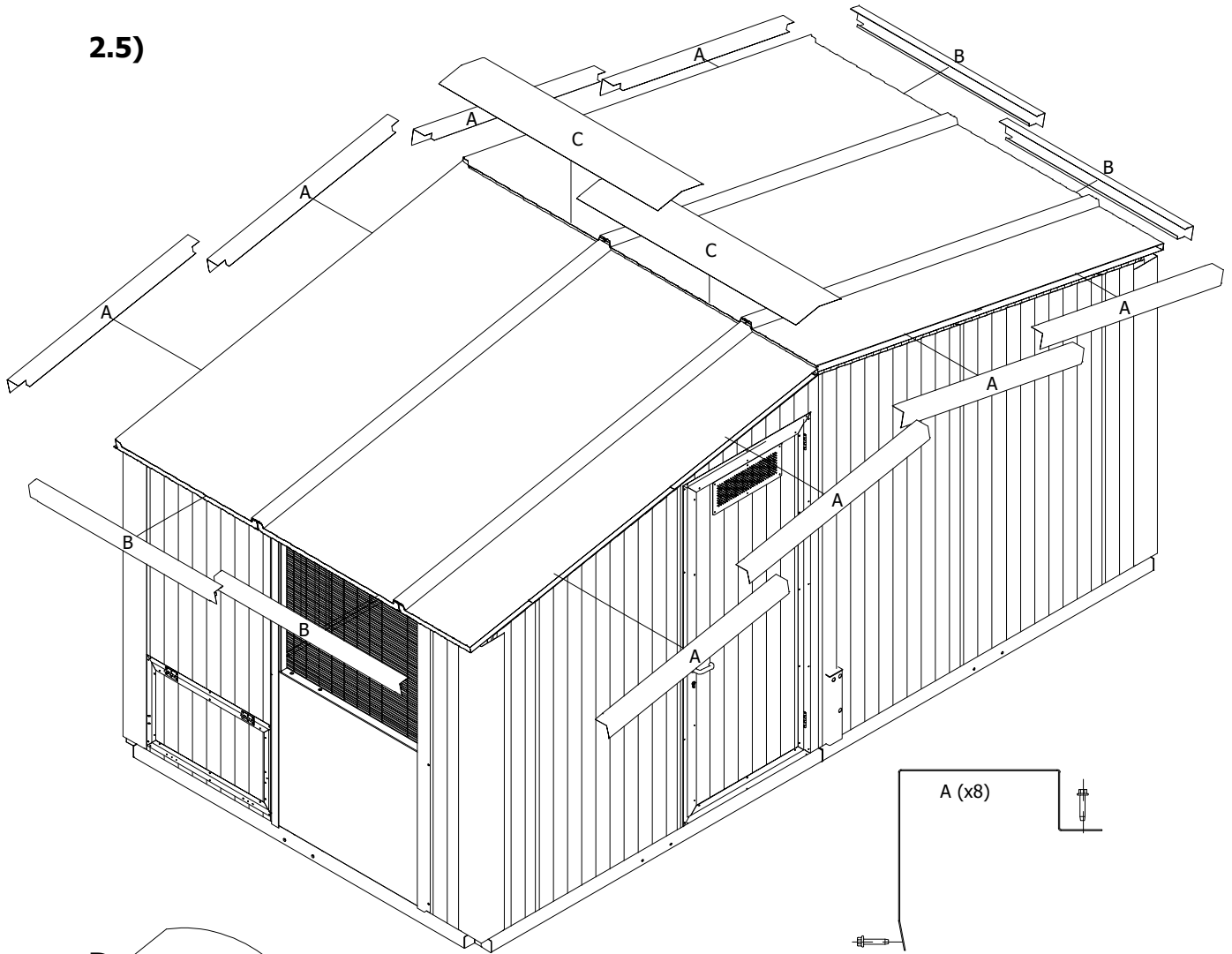

DIN 7504 5.5x22 (x64)

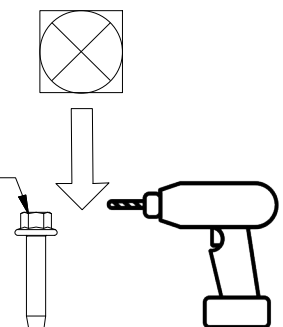

RESULTADO:

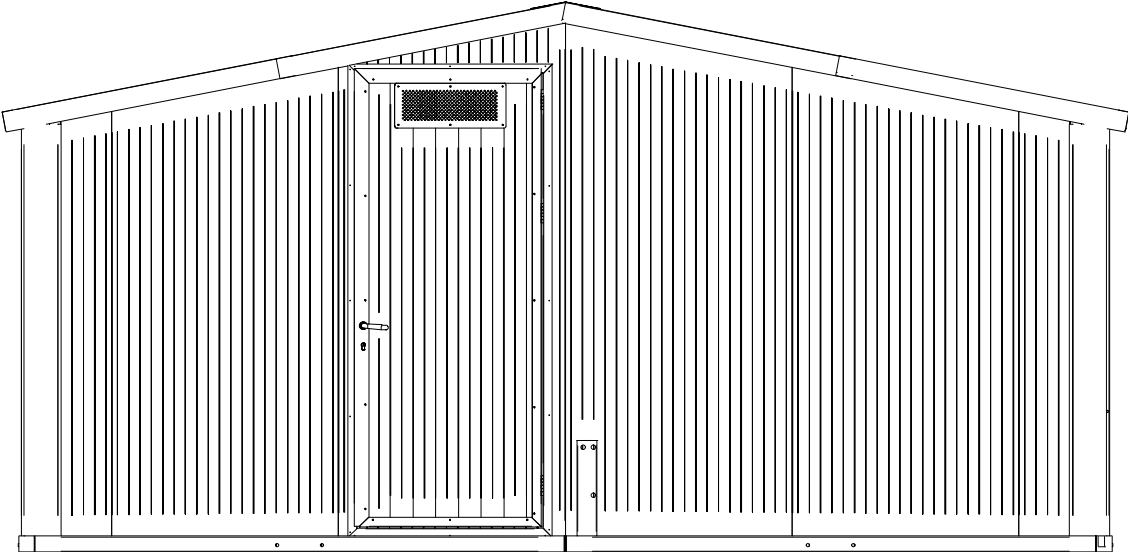
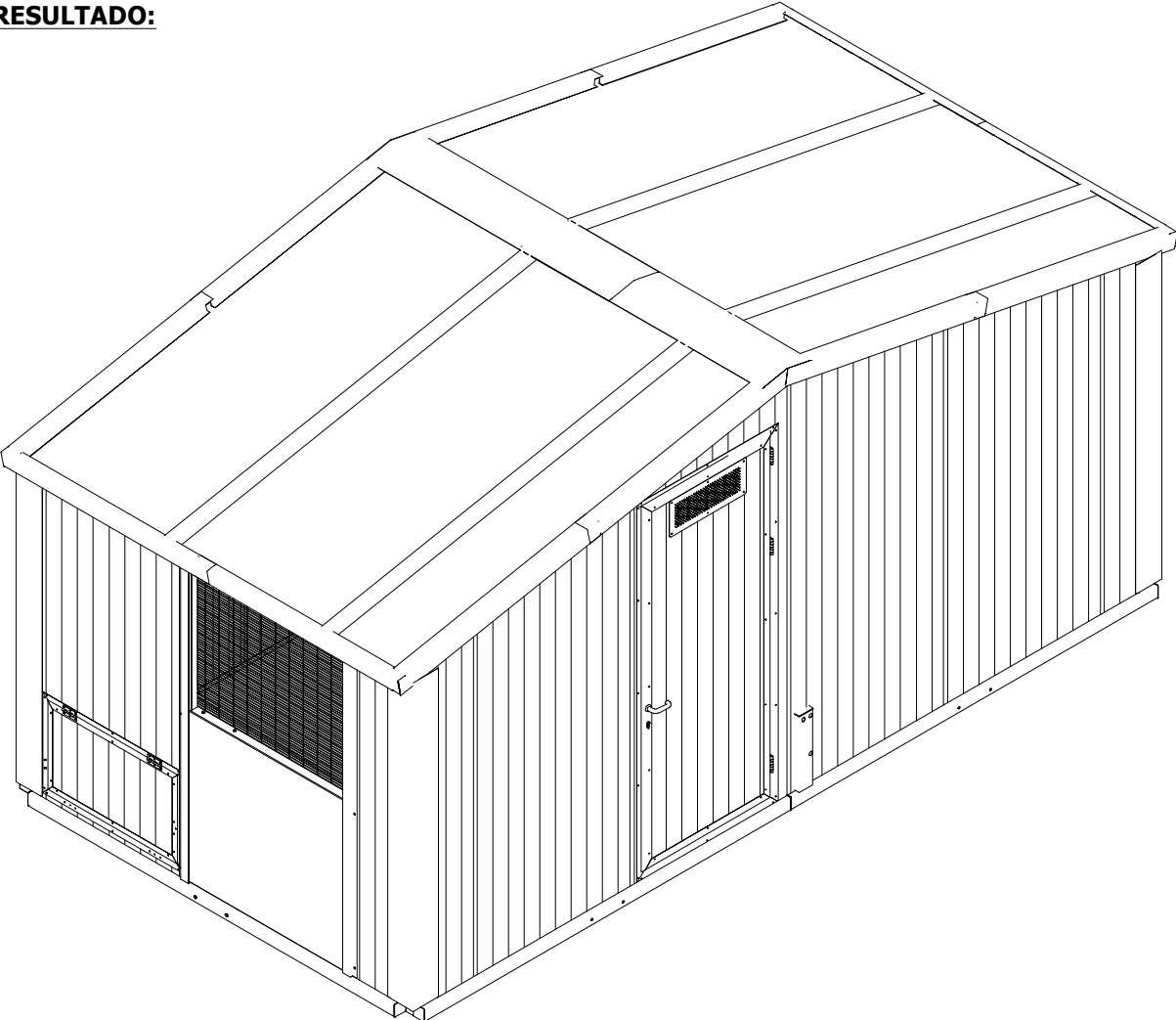

KIT DESPLAZAMIENTO:

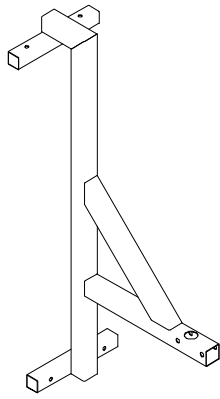

Estructura tiro 1 Uds

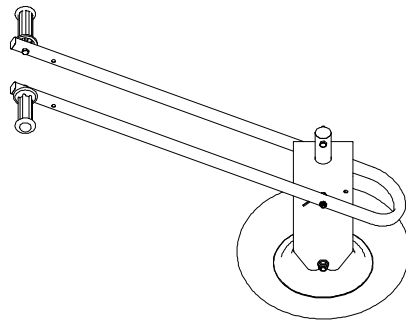

Rueda giratoria 1 Uds

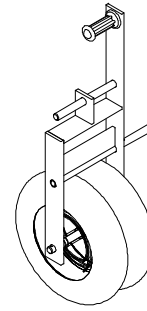

Rueda montada V2 2 Uds

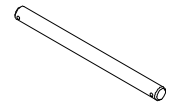

Bulón pasador 2 Uds

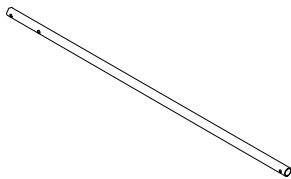

Tirante 2 Uds

ACCESORIOS:

ACCESORIOS KIT DESPLAZAMIENTO		
CÓDIGO	DESCRIPCIÓN	UNIDAD
77000100	TORNILLO DIN 931 M8x60	7
77230600	ARANDELA DIN 125 M8	12
78120400	PASADOR DIN 94 3.2x30	8
77026600	TORNILLO DIN 931 M8x70	2
77110400	TUERCA DIN 934 M8	3

FASE 3:

3.1)

DIN 931 M8x60 (x4)

DIN 125 M8 (x4)

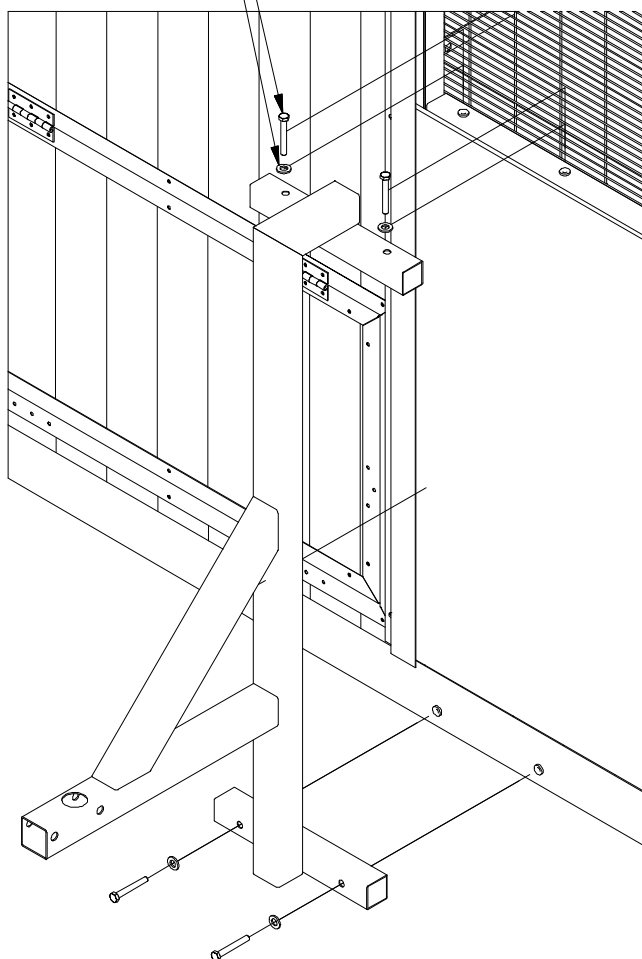

3.2)

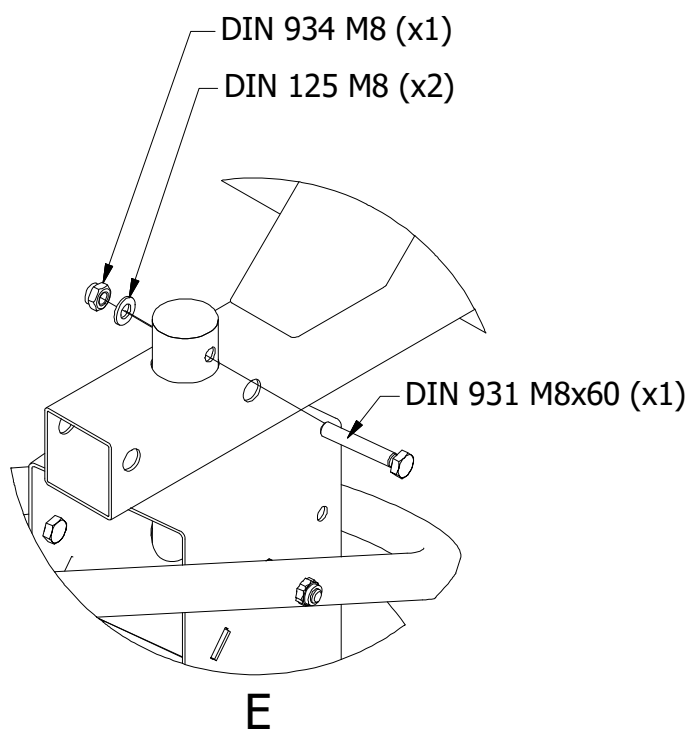
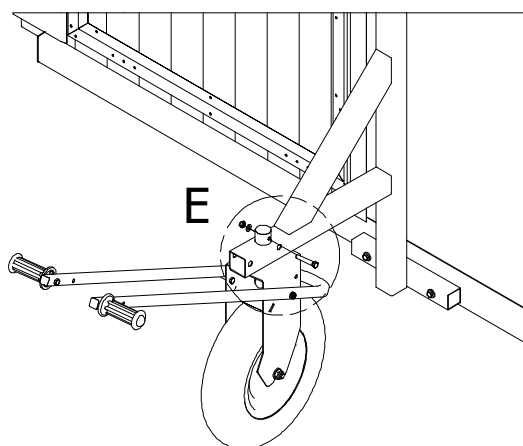

3.3) (X2)

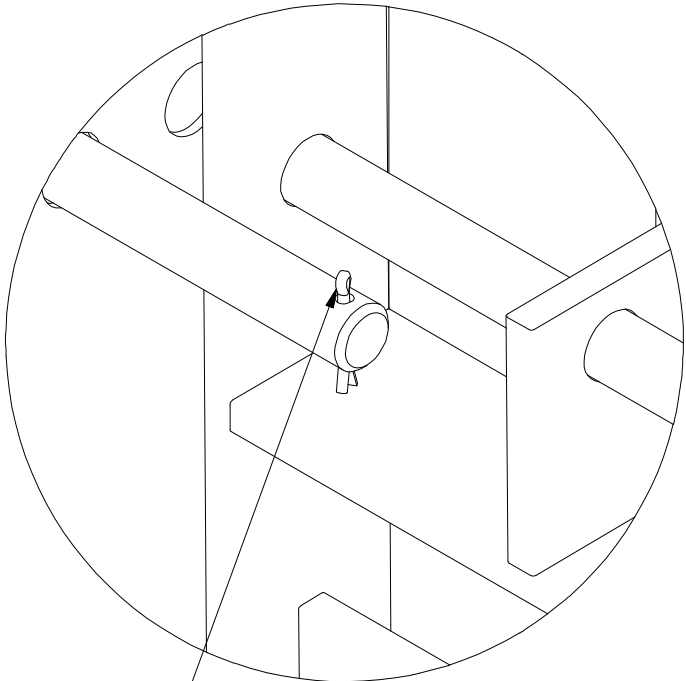
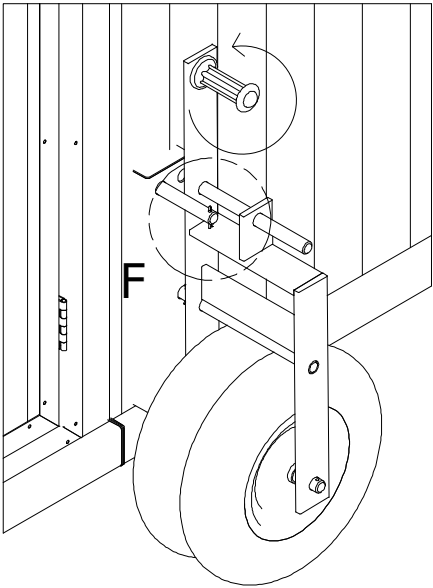
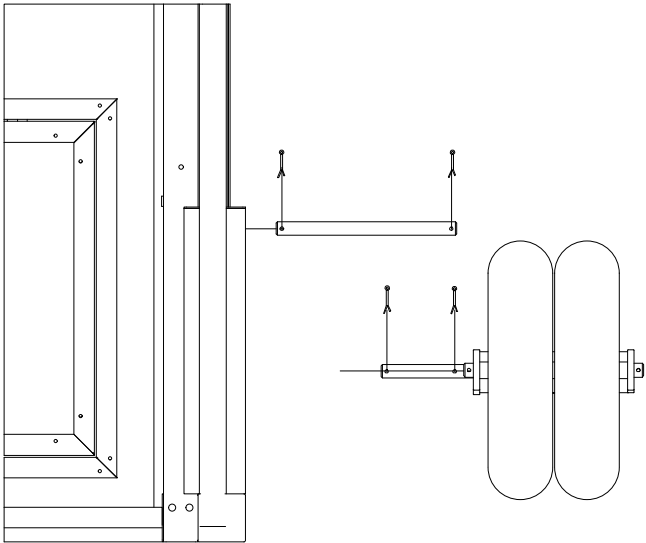
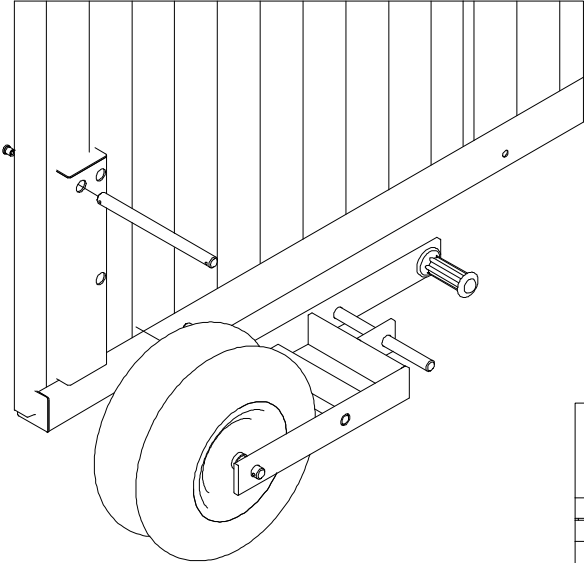

PASADOR DIN 94 3.2x30 (x8)

F

3.4) (x2)

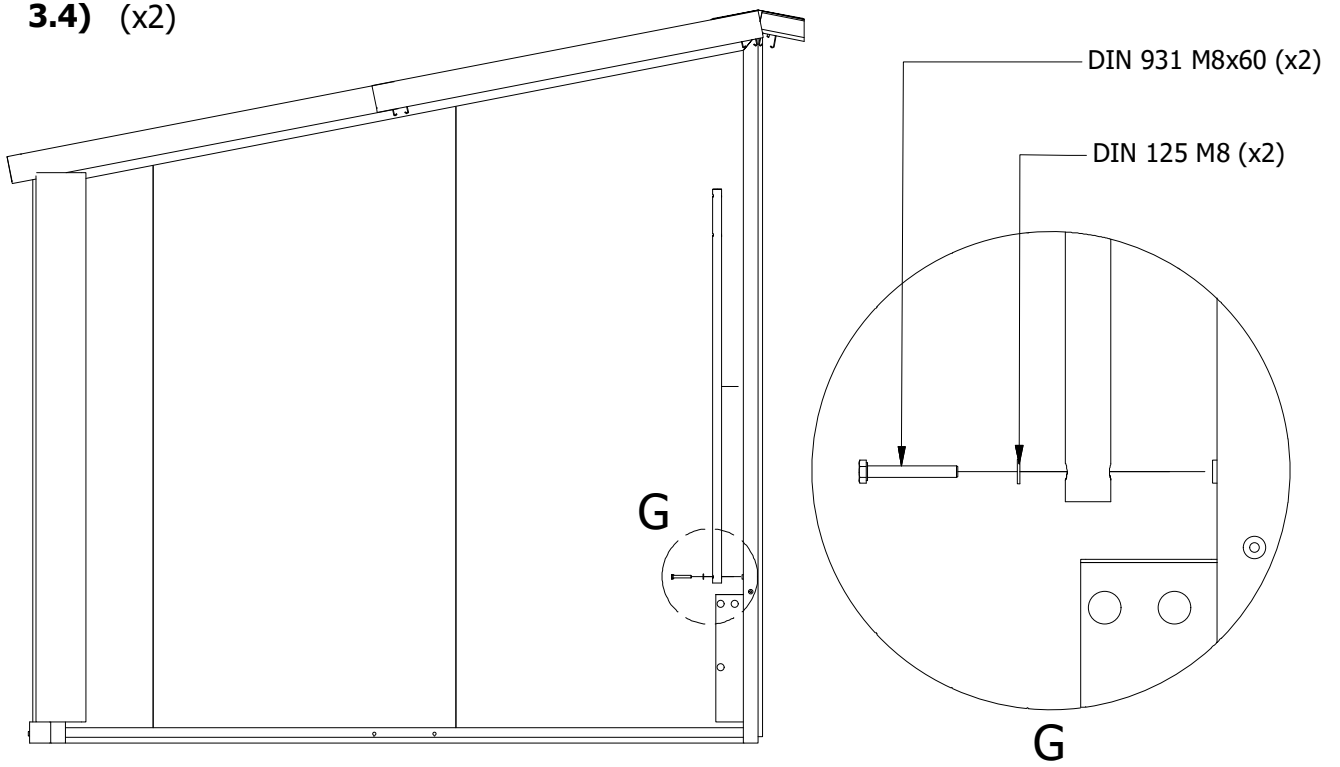

3.5) ↕

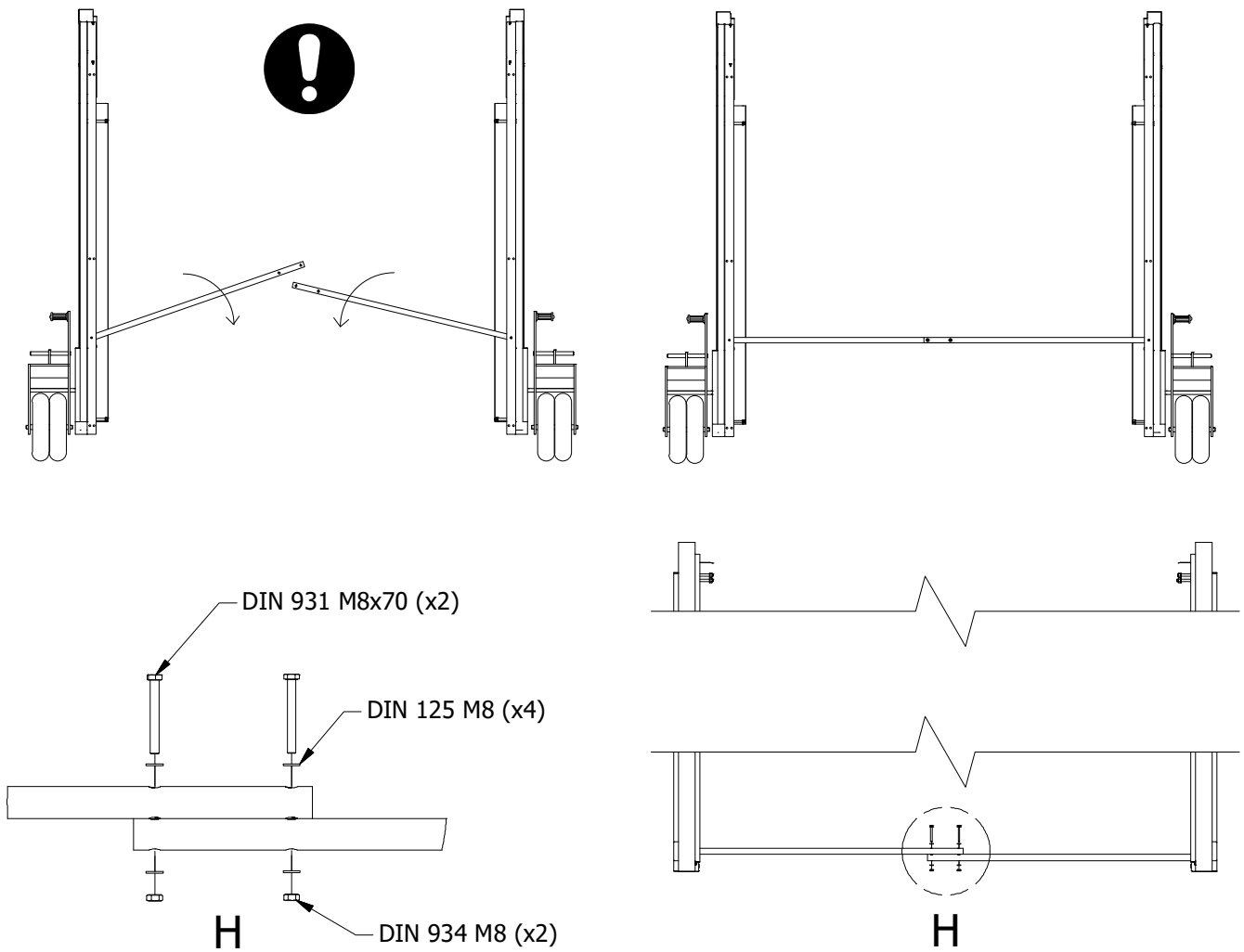



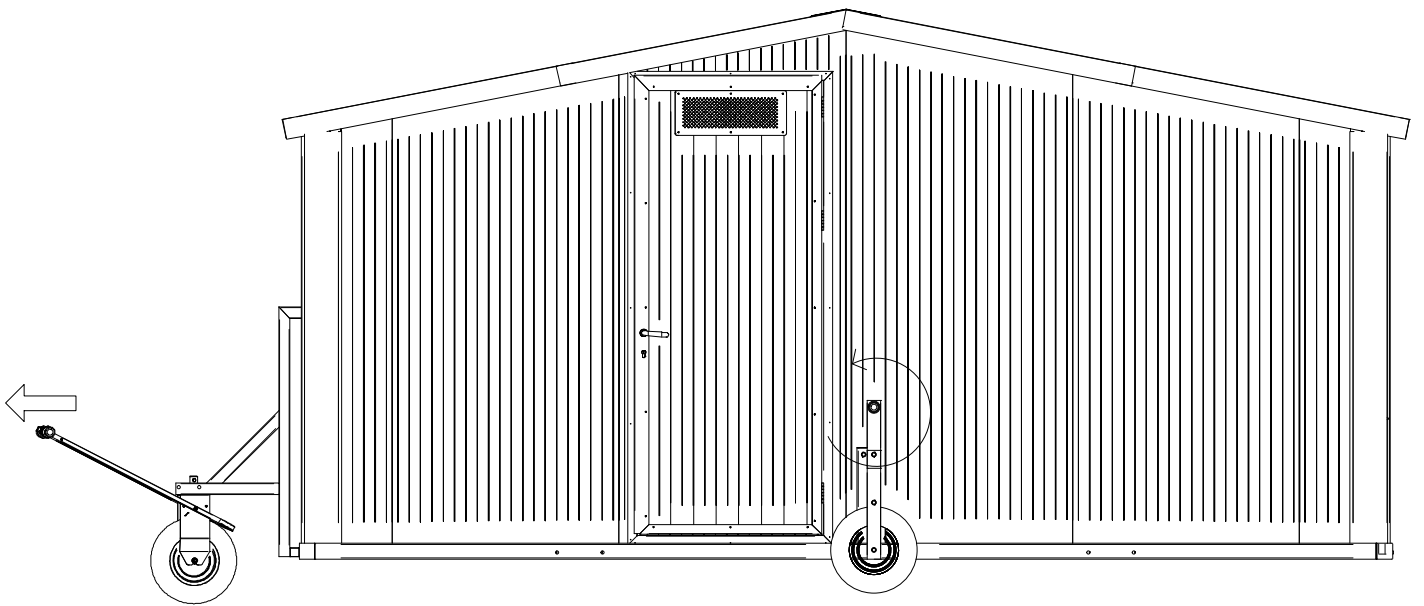
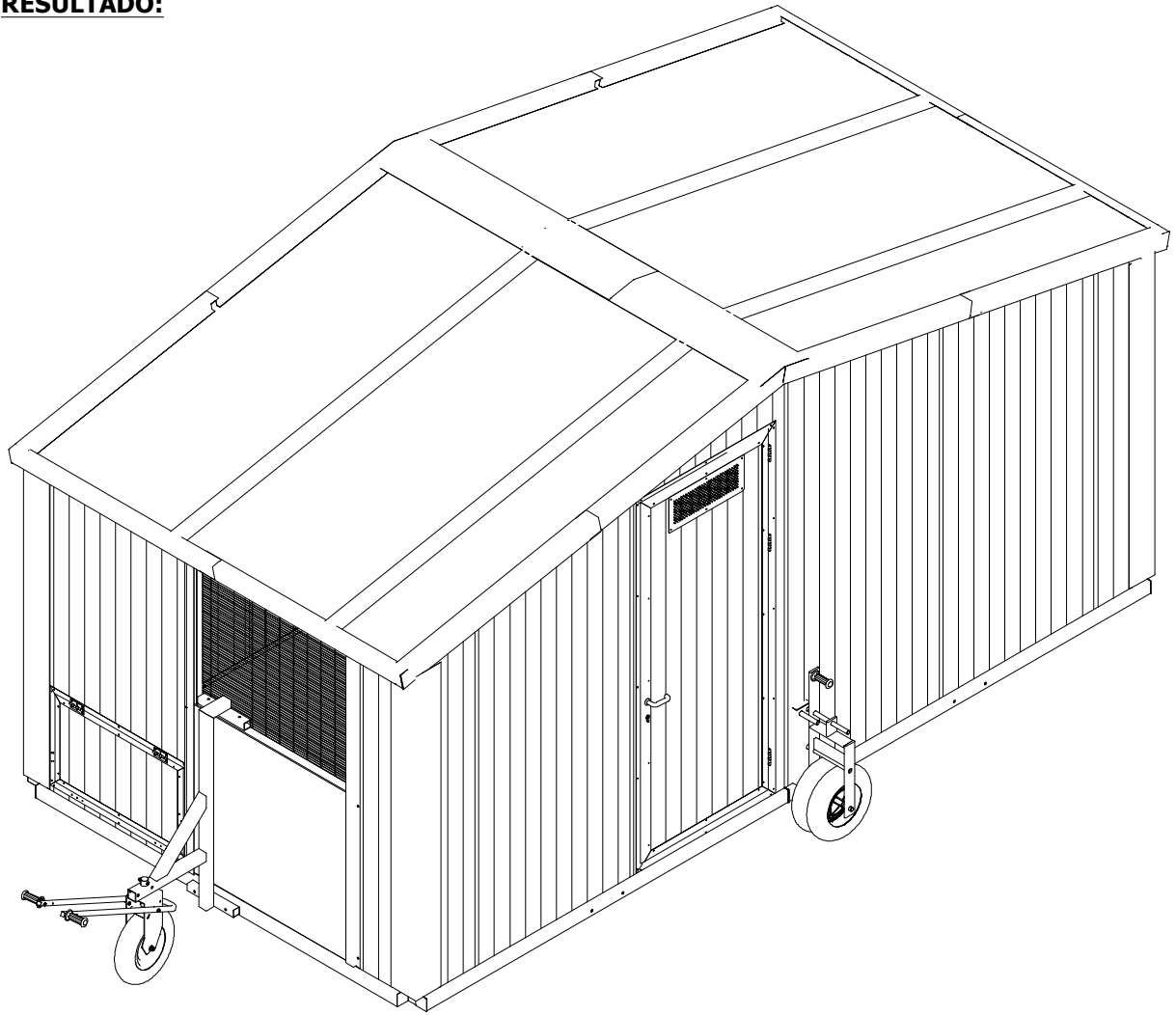

RESULTADO:



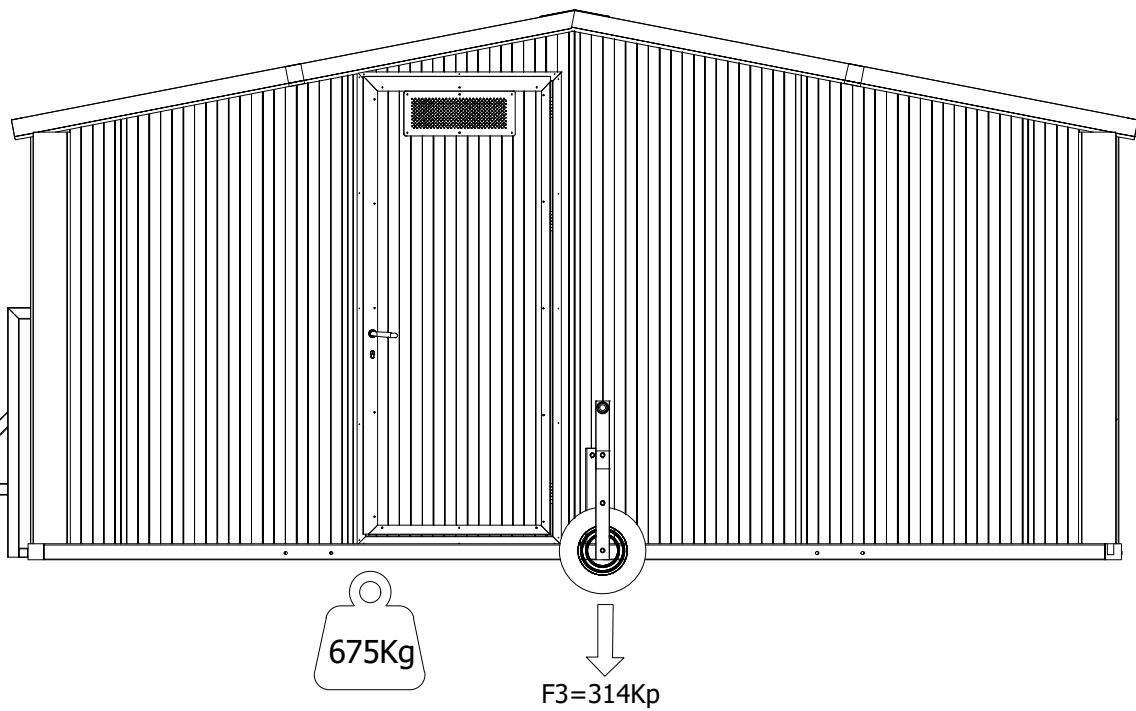
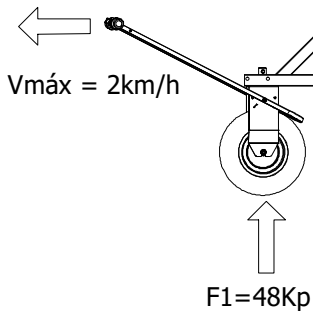

2



 Pendiente	 Viento (Km/h)	 Nieve (máx (cm))
1% ($h_{máx} = 5\text{cm}$)	$V_{máx} = 100$	$e = 30$
3% ($h_{máx} = 15\text{cm}$)	$V_{máx} = 40$	$e = 30$

